



长驰科技
Z-Gallop Technology



行星齿轮减速机驱动解决方案
Planetary Gearbox Drive Solution





建筑行业
破碎设备
环保工业
采矿工业
港口设备
通讯工业
造纸工业
电力设备
游乐设备
化学搅拌工业
海洋船舶工业
金属制品工业

Construction Industry
Crusher
Environmental
Mine equipment
Port equipment
Communication
Paper mill
Power
Amusement
Blender
Marine
Metal equipment

公司简介

长驰传动科技(苏州)有限公司成立于2017年,坐落在美丽的江南水乡江苏省苏州市昆山市,这是个朝气蓬勃的城市,有着优越的地址位置毗邻上海和苏州市。企业以年轻化团队为主,积极向上、勇于拼搏,同时企业也一直本着务实的精神借助中国经济发展的潮流不断的壮大。在实践中一步一个脚印,在市场中接受考验,目前企业已经具有稳定的市场,也沉淀了雄厚的技术设计及应用能力,能够适用及引领市场需求。

目前企业主要从事齿轮及传动产品的设计、研发、生产及销售;本公司坚持技术自主,创新研发的原则,核心技术业务完全有我司自主设计。产品主要包括:行星齿轮减速机、伞齿弧齿轮直角齿轮箱、分动箱、非标齿轮箱、双速齿轮箱、液压制动器、离合器及相关配套齿轮及传动轴,同时本公司可提供产品实行监控系统等,实现产品物联网。

我司产品已经使用于矿山设备、工程机械、船舶工业、地下钻探设备、军工产品、环保设备、电力设备等,市场使用稳定,质量可靠;面对激烈的国内外市场竞争环境,我们提供更高性价比的产品,我们有信心取得优异的成绩和更好的中国制造。



文化宣言:品质驱动未来
Company Culture: Quality Drive Future

Company Profile

Z-Gallop Equipment Tech.(SuZhou) Co., Ltd. build in 2017, It is local in beautiful KunShan City in South of China, The KuanShan is a full of youthful spirit city and has superior location nearby ShangHai and SuZhou. Company mainly depend younger team with positive and struggle spirit, also we always to keep pragmatic spirit to work hard and expending by Chinese economy development. Step by step in practice and ordeal in market, so now we have steady business, abundant technical and profession application to satisfy market.

Company mainly working on gear transmission produce design, research development,manufacture and sales. Our contains business: Planetary gearbox, Bevel gear right angle gearbox, Transfer gearbox, Special gearbox, Two speed Transfer gearbox, Hydraulic static brake, Cluth, Transmission shaft and interrelated gear and shaft, Also we can offer Real-time Monitoring System(RTMS) ,perform Internet of Things.

These produces use on mine equipment, engineering machinery, marine industry, underground equipment and military produce, environmental equipment, power equipment and so on. Our produces has good quality and performance in application; Facing fierce domestic and overseas competition market, we have higher cost performance product, we have confidence to got excellent performance and more better Made in China.

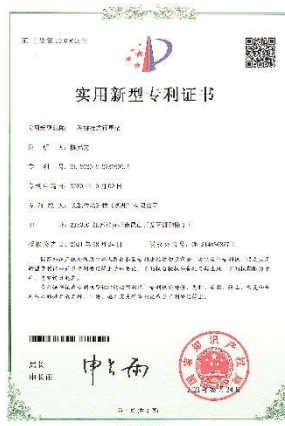

产品类型



回转类减速机

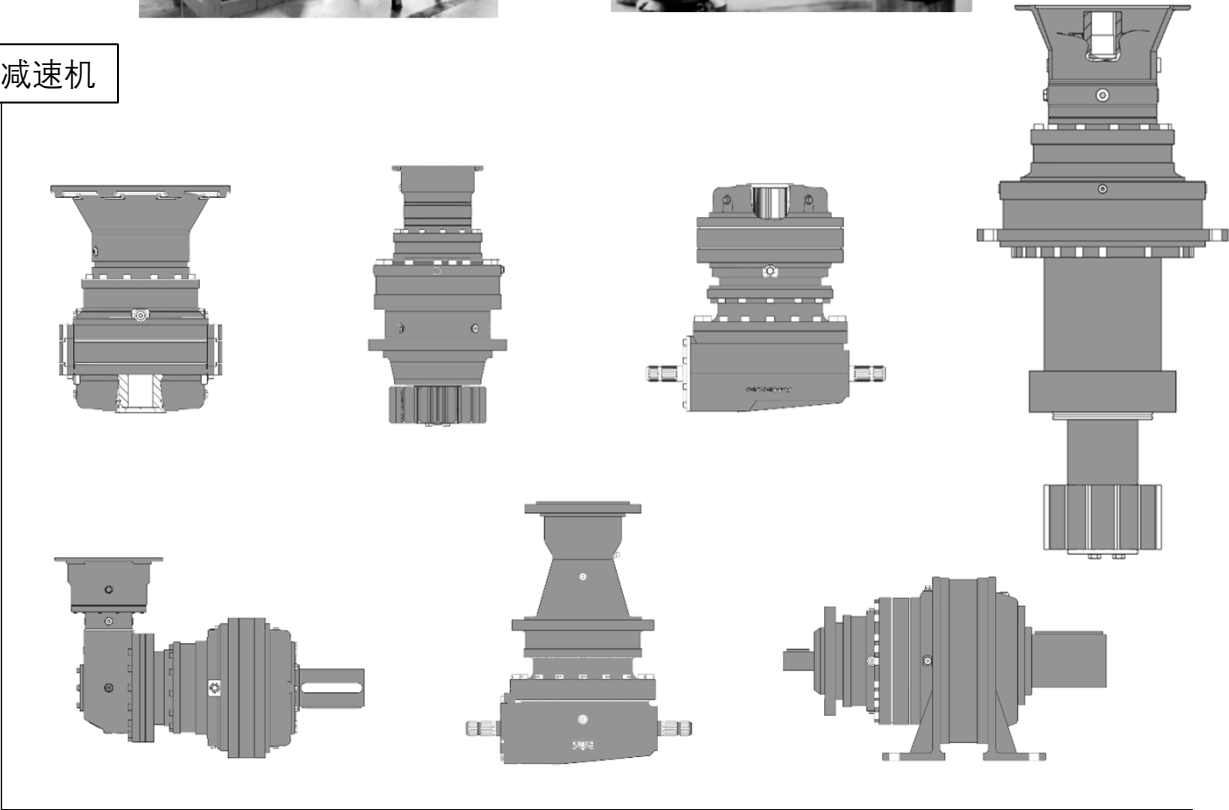

卷扬类减速机

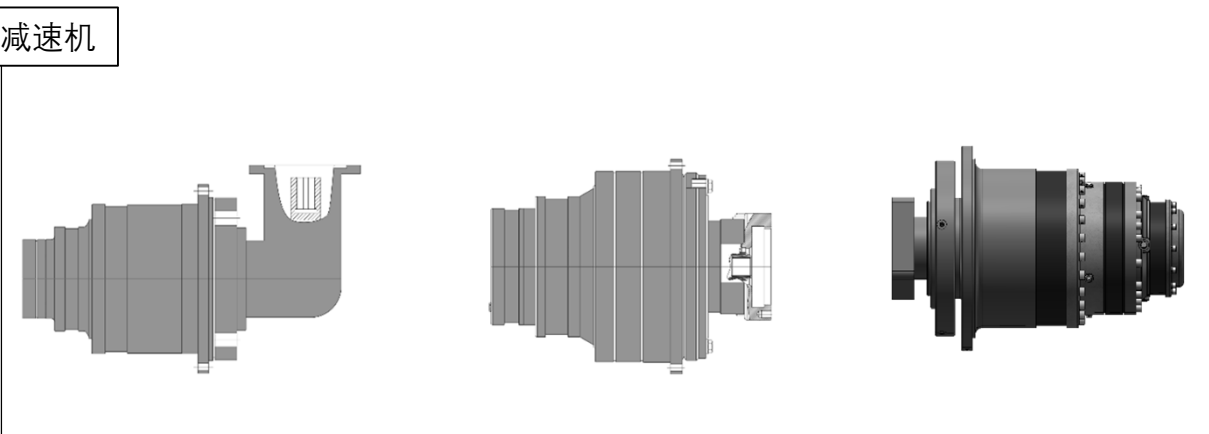

齿轮箱

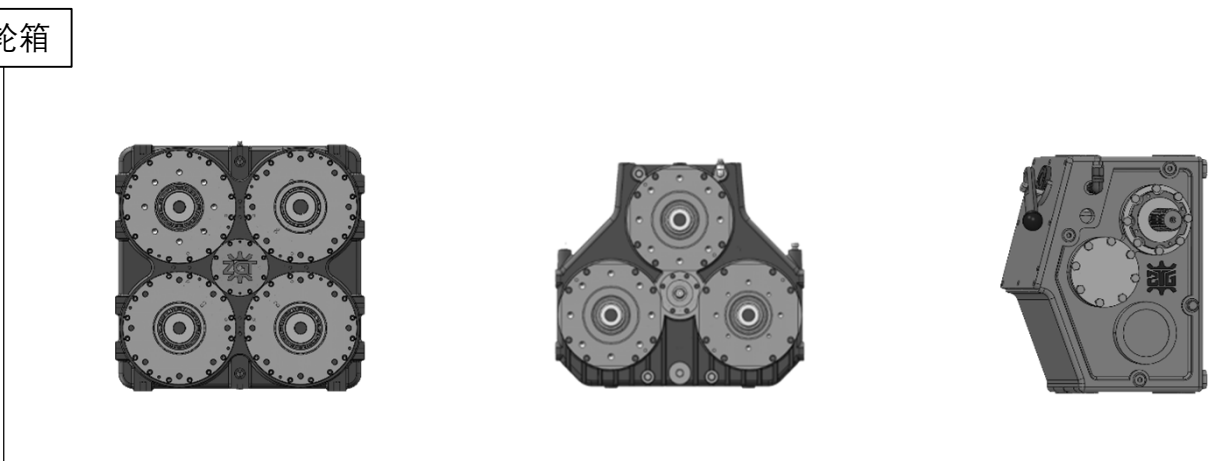

符号说明 Symbol Description					
符号 Symbol	单位 unit	说明 Description	符号 Symbol	单位 Unit	说明 Description
T1	NM	输入扭矩 Input torque	Pb	Bar	制动器开启压力 Open Pressure
T2	NM	输出扭矩 Output torque	Pbmax	Bar	制动器最大承载压力 Max. load Pressure
Tf	NM	制动力矩 Brake torque	B	mm	齿轮厚度 Pinion width
Tcont	NM	持续输出扭矩 Continue torque	M	mm	齿轮模数 Pinion Module
Tmax	NM	最大输出扭矩 Max. output torque	Z	-	齿数 Pinion Teeth
n1	Rpm	输入转数 Input speed	X	-	变位系数 Pinion modification
n2	Rpm	输出转数 Output speed	α	-	压力角 Pinion pressure angle
N1max	Rpm	最大输入转数 Max. input speed	η	-	效率 Efficiency
N2max	Rpm	最大输出转数 Max. output speed	η_m	-	机械效率 Mechanical Efficiency
P1	KW	输入功率 Input power	η_v	-	容积效率 Volume Efficiency
Pt	KW	热功率 Thermal capacity	e	mm	偏心量 Eccentricity
Pt1	KW	实际热功率 Actual Thermal capacity	fs	-	服务系数 Service Factor
I	-	速比 Ratio	V	CC	马达排量 Motor Displace
h	H	工作小时 Lifetime in hours	P	Bar	压力 Motor Pressure
Fa	N	轴向载荷 Axial Load	Q	L	流量 Motor Flow
Fr	N	径向载荷 Radial Load	Tem	°C	温度 Temperature
W	Kg	重量 Weight	Gc	L	加油量 Contain oil

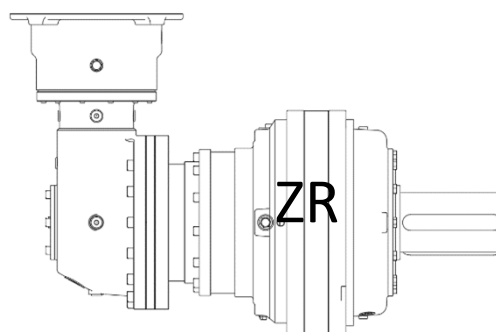
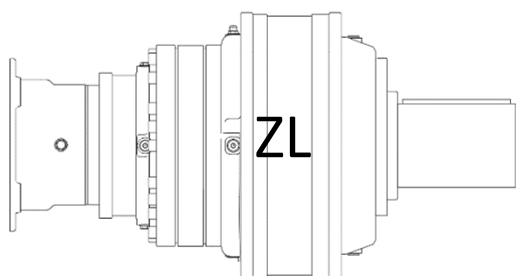

概述

随着工业的发展，工业行星减速机的应用也越来越广泛，其主要特点是其体积小，传动扭矩大，传动效率高，速比广，安全性高，主要被用来降低转速增大扭矩。行星齿轮减速机主要传动结构为：行星轮，太阳轮，内齿圈，行星架。

我公司行星齿轮箱采用模块化设计，有直线型ZL和直角型ZR，不同速比通过固定行星组模块组合而成，可以实现速比选择的灵活性及广泛性，从一级减速到五级减速，直线型减速机速比范围3.0—5000，直角型减速机速比10—5000，如有特殊需要还可以调整速比范围。本样本介绍行星减速机19种规格，扭矩范围500—30万牛米，热功率覆盖到100KW，我司最大减速机输出扭矩为100万牛米，功率达到600KW。订制减速机扭矩最大为300万牛米。

行星减速机驱动主要是液压马达、电机，连接可以通过直连或者联轴器形式，减速机输出有齿轮输出、花键轴、平键轴、内花键、六方轴、涨紧套等形式，安装方式有法兰、脚座、扭力臂等形式。同时为满足市场需求，我公司自行设计并生产与行星减速机配套的液压静态制动器，离合器，双速单元等产品，与行星齿轮箱输入实现无缝对接，更好的适应于不同应用场合。

1. 技术定义

1-1 减速比

i = 减速比 速比是齿轮箱输入速度与输出速度之间的关系

$$i = n_1/n_2$$

1-2速度

n_1 = 输入速度：齿轮箱的输入转速

n_2 = 输出速度：齿轮箱的输出速度；

$$n_2 = n_1/i_e$$

1-3 使用寿命

$n_2 \cdot h$ = 输出持续时间指标:

输出速度与持续时间（小时为单位）的乘积。它说明了齿轮箱的使用寿命与其所承受的驱动力成比例。为了使速度与持续时间相关联， $n_2 \cdot h$ 的函数形式表示扭矩 T_{cont} 当速度 n_2 和扭矩 T_{cont} 可知时，就能计算出持续时间（小时为单位），同样如果速度与持续时间可知时，那么齿轮箱的传递扭矩 T_{cont} 也能计算出。

Profile

With the development of industry, the application of industrial planetary reducer is becoming more and more extensive. Its main characteristics are its small size, large transmission torque, high transmission efficiency, wide speed ratio, and high safety. It Mainly used to reduce the speed to increase the torque the main transmission structure of planetary gear reducer is: planetary gear, sun gear, ring gear, planet carrier.

Our company's planetary gearbox adopts a modular design, with linear ZL and right-angle ZR. Different speed ratios are combined by fixed planetary group modules, which can achieve the flexibility and extensiveness of speed ratio selection. the reducer can achieve one to five speed reduction through modular design. Linear planetary reducer speed ratio range of 3.0-5000, Right-angle planetary reducer speed ratio range of 10-5000, You can also adjust the speed ratio range to meet your special needs. This sample introduces 19 specifications of planetary reducer, with a torque range of 500 to 300,000 Nm, and the thermal power covers 100KW. Our company's maximum reducer output torque can reach 1 million Nm, and the power 600KW. The specially demand cover 3 million Nm.

The planetary reducer is mainly driven by hydraulic motors and motors. The reducer can be connected directly to the drive or through a coupling. reducer has multiple output forms including gear shaft, spline shaft, flat key shaft, internal spline, hexagonal shaft, tension sleeve, etc. Installation way has flange, foot, torque arm and other forms. At the same time, in order to meet the market demand, our company designs and produces the hydraulic static brakes, clutches, two speed unit and other products supporting the planetary reducer by itself, and seamlessly connects with the input of the planetary gearbox to better adapt to different applications.

1. Technical definitions

1-1 Reduction ratio

i = Reduction ratio effective reduction ratio:

ratio between the input and output velocity of the gearbox

$$i = n_1/n_2$$

1-2 Speed

n_1 = input velocity: is the input velocity of the gear box

n_2 = output velocity: is the output velocity of the gear box; $n_2 = n_1/i_e$

1-3 Lifetime

$n_2 \cdot h$ = output duration index:

product of the output velocity and the duration in hours. It represents a number proportional to the

$n_1 \cdot h$ = 输入持续时间指标:
 输入的速度与持续时间 (小时为单位) 的乘积, 它是用来计算输入轴轴承的持续时间。如果知道速度 n_1 , 施加的负载和应用点, 那么持续时间就能通过计算得到。

1-4 功率

P_t = 热功率:
 带飞溅润滑, 持续运转不超过发热极限时 (油温不大于90摄氏度时) 齿轮箱能传递的最大机械功率。如使用适当的降温系统, 可以传递最大的功率。这个值在齿轮箱连续运转与下列条件有关: 各减速级机械效率为0.97、输入速度为1500rpm、环境温度为20摄氏度、海拔高度为0-500米, 应用于表面安装。在不同的条件下, 热功率值必须乘以对应的热系数。在有限的运转周期情况下, 如有足够长的停机时间来保证齿轮箱的充分的冷却, 这样热功率就失去了意义, 并可以忽略不计。如果齿轮箱热功率不够可以增加冷却系统, 帮助齿轮箱散热。

stress applied to the element which limits the life of the gearbox. To correlate the velocity and the duration, the torque T_{cont} is expressed as a function of the product $n_2 \cdot h$. With the speed n_2 and the torque T_{cont} required, the duration in hours can be calculated; or alternatively, if the speed and the duration in hours required are known then the T_{cont} that the gearbox can transmit can be calculated

$n_1 \cdot h$ = input duration index:
 is the product of the input speed and the duration expressed in hours.
 It is used to calculate the duration of the bearings of the input supports.
 If you know velocity n_1 , the loads applied and the application point, the duration in hours can be obtained.

1-4 power
 P_t = thermal power:
 maximum mechanical power that the gearbox can transmit while operating continuously, with splash lubrication, without exceeding the thermal limit (oil temperature not greater than 90°C). Greater powers can be transmitted by using an appropriate cooling system. The value refers to a continual operation with mechanical efficiency of 0,97 for each reduction stage, input velocity of 1500 rpm, ambient temperature of 20°C, altitude 0 / 500 m, application to the cover. For different conditions, the thermal power value must be multiplied by the thermal factors. For limited operating periods, followed by rest periods that are sufficiently long to guarantee an adequate cooling of the gearbox, the thermal power loses itsance and can be disregarded.

K: 工作时间与温度服务系数 Work cycles requiring and ambient temperature factor					
每天工作小时 HOURS/DAY	环境温度 Ambient temperature °C				
	10	20	30	40	50
2	1.8	1.6	1.4	1.25	1.1
4	1.6	1.4	1.25	1.1	1.0
6	1.4	1.25	1.1	1.0	0.85
8	1.25	1.1	1.0	0.85	0.7
10	1.15	1.0	0.85	0.7	0.6

S:输入速度服务系数 Input speed factor				
	N1 rpm			
	500	1000	1500	2000
S	1.1	1.05	1	0.9

R:安装空间服务系数 Located space factor			
	狭窄空间 Small space	宽敞空间 Lange space	室外空间Outdoors
R	0.7	1.0	1.3

通用的计算减速机热功率:

In the most general case the adequate thermal rating of the gearbox unit will be:

$$P_{t1} = P_t \cdot K \cdot S \cdot R$$

1-5 扭矩

T_{cont} = 持续扭矩
 在连续运转中, 齿轮箱的可传递扭矩。
 在齿轮箱输出转速为 "n₂" RPM时, T_{cont}
 保证齿轮箱的持续寿命为 "h" 持续扭矩
 T_{cont} 以n₂ · h的函数形式表示。

T_{max} = 最大扭矩
 齿轮箱在短时间内能传递的扭矩最大值。

1-6 效率

η_m = 机械效率: 输出功率与输入功率比值;
 一般被认为每个减速级中等于0.97~0.98,
 用来弥补齿轮箱的消耗; 它取决于各种因素,
 如速度, 扭矩, 减速比, 工作位置, 和润滑。

1-7 齿轮箱工作噪音

齿轮箱加入适量润滑油, 输入转数
 1500rpm, 四级传动齿轮箱, 在环境温度
 25℃, 工作温度45℃时, 在非静音环境中
 测试齿轮箱运转噪音约为45DB。

2. 动力的选择

2-1 液压马达驱

如果知道液压回路压力P (马达工作压力
 差)、扭矩T₁ 齿轮箱所需要的输入速度n₁,
 那么马达的排量V一定大于等于

$$V = \frac{20 \cdot \pi \cdot T_1}{P \cdot \eta_m}$$

其中 η_m 是马达的机械效率; 必须供给的流
 量Q是

$$Q = \frac{V \cdot n_1}{1000 \cdot \eta_v}$$

2-2 电机/发动机驱动

在电机持续负载工作时, 知道齿轮箱的机
 械效率 η_m 、扭矩T₂和输出速度n₂, 那么电
 机马达的实际功率一定大于:

$$P = \frac{T_2 \cdot n_2}{9550 \cdot \eta_m}$$

对于有特殊负载工况的, 在选型之前提
 出。

1-5 Torque

T_{cont} = continuous torque:
 Transmittable torque of the gearbox, with continuous
 operation, that guarantees a duration of 'h' hours,
 with gearbox output rotation velocity of 'n₂' RPM.
 T_{cont} is expressed as a function of the product n₂ · h.

T_{max} = Maximum torque
 The maximum torque that the gearbox can
 transmit in a short time.

1-6 Efficiency

η_m = mechanical efficiency:
 ratio between the output power and input power;
 normally it is considered to be equal to 0,97 ~0,98 per
 reduction stage that makes up the gearbox; it
 depends upon various factors, of which velocity,
 torque, ratio, working position and lubrication.

1-7 Gear box working noise

When the gearbox is added with an appropriate
 amount of lubricant, the input speed is 1500rpm, the
 four-stage transmission gearbox, and the non-quiet
 environment, the test gearbox runs at about 45dB.

2. Power election method

2-1 Hydraulic motor drives

Knowing the hydraulic circuit pressure, from which the
 Dp of the motor can be obtained, the torque T₁,
 the velocity n₁ required at the input of the gearbox,
 the hydraulic motor capacity must be greater or equal
 to:

$$V = \frac{20 \cdot \pi \cdot T_1}{P \cdot \eta_m}$$

where η_m is the mechanical efficiency of the motor.
 The necessary supply flow rate is:

$$Q = \frac{V \cdot n_1}{1000 \cdot \eta_v}$$

2-2 Electric drives

When the motor is continuously working, knowing
 the mechanical efficiency η_m , torque T₂, and output
 speed n₂ of the gearbox, the actual power of the
 motor must be greater than:

$$P = \frac{T_2 \cdot n_2}{9550 \cdot \eta_m}$$

For those with special load conditions, put forward
 before the selection.

3.静态制动器

3-1概述

制动力通过弹簧压缩钢圆盘与铜圆盘，产生摩擦作用，这种推压力被转换成制动扭矩。制动力的释放通过施加液压力到制动器中来实现；压力推动活塞压缩弹簧，使制动盘可以自由的旋转，当液压力为零时制动器处于静止关闭状态，当液压力达到释放的开启值时，制动器打开。齿轮箱内部润滑油不提供制动器润滑，因此必须注入（0.1升）粘度指标为ISO VG32的润滑油，或者换用其他合适的润滑油。

制动器的开启需要满足完全开启压力，否则制动片容易损坏。

3-2制动器的选择

—制动器扭矩 T_f 必须大于或者等于马达扭矩 T_1 ：

$$T_f \geq T_1$$

—制动器扭矩乘以减速比再除以齿轮箱的输出扭矩效率，必须大于或者等于输出扭矩 T_1

$$T_f \cdot i = / \eta_m \geq T_2$$

4安装说明

4.供货说明

4-1 齿轮箱供货时不带润滑油。

在使用前，齿轮箱必须用推荐的润滑油装填至所示的油位。按照实际产品油位计标识。如需带油供货，请在订货前特别说明。

4-2 油漆

齿轮箱供货时加工面经防锈油处理，通常环境下可以保存12个月不生锈。未加工面做防锈底漆处理，理论上可永久防锈。如需特殊喷漆请在订货前特别说明。

4-3 存放

齿轮箱不得存放在露天或直接与地面接触。如要长时间存放，必须内部装满油并在外部运转部分涂抹一层油脂，连接法兰用抗氧化剂保护，同时还应注意每月空载转动（输出轴能充分的完全旋转）。

4-4 包装

整机产品出厂均为我司定制木箱包装，木箱不回收。如需特殊包装请在订货前特别说明。

5.润滑使用说明

5-1润滑油加注

齿轮箱通过油来进行润滑；启动齿轮箱前必须加注润滑油，同时利用油位指示标志，确保达到正确的油位；请注意运行

3. Static Brake

3-1 Overview

Braking is generated by springs, which compress fixed alternating tempered steel discs against bronze mobile discs; this thrust is transformed by friction into a braking torque. Brake releasing is achieved by the injection of hydraulic pressure into the brake; the pressure acts upon a piston, which compresses the springs, thus enabling the disc to rotate freely. The brakes are therefore static and closed when hydraulic pressure is zero and they open when the hydraulic pressure reaches the opening values for release. The brakes are not lubricated by the oil from the gearbox. It is necessary to carry out the filling with mineral oil(0.1L) of a viscosity ISO VG32; or as an alternative it is possible to use hydraulic oils.

3-2 Brake selection

The brake torque T_f must be greater or equal to that of the motor torque T_1

$$T_f \geq T_1$$

The brake torque multiplied by the reduction ratio and divided by the output of the gearbox, must be greater or equal to output torque T_1

$$T_f \cdot i = / \eta_m \geq T_2$$

4 Delivery instruction

4-1 Delivery instructions

The gearbox is supplied without lubricant. Before use, the gearbox must be filled with the recommended oil to the indicated oil level. Mark according to the actual product oil level gauge. For delivery with oil, please specify before ordering.

4-2 paint

When the gear box is delivered, the processing surface is treated with anti-rust oil, and it can be stored for 12 months under normal environment without rust. The unprocessed surface is treated with anti-rust primer, which can theoretically prevent permanent rust. For special spray paint, please specify before ordering.

4-3 Store

The gearbox must not be stored in the open air or in direct contact with the ground. If it is to be stored for a long time, it must be filled with oil internally and coated with a layer of grease on the external running part. The connection flange is protected with antioxidants. At the same time, it should be paid attention to monthly no-load rotation (the output shaft can fully rotate fully).

4-4 package

The reducer is packed in a customized wooden box by our company. The wooden box is not recycled. For special packaging, please specify before ordering.

5 lubrication instructions

5-1 Lubricant filling

The gearbox is lubricated by oil; it must be filled with lubricant before starting the gearbox, and the oil

几分钟后必须再次检查油位，确保一切正常。

5-2 润滑油的选择

选择用于机械传动带有EP添加剂的各种润滑油均可使用，润滑油符合standards ISO3448/SAE 80 - 90W/ SAE J 306-81标准，粘度等级符合VG68和VG220。在特殊情况下可以根据实际工作条件选择合适润滑油，推荐使用合成润滑油，特殊要求也可与我司联系。对于对于垂直安装方式的减速机，可以选择加装扩展油箱，以保证减速机所有内部零件有充分的润滑，我司可以提供此油箱。

level indicator must be used to ensure that the correct oil level is reached; please note that the oil level must be checked again after a few minutes of operation to ensure that everything is normal

5-2 Choice of oil

Any type of oil for mechanical transmissions can be use with EP additives that satisfy the VG68 and VG220 viscosity classes according to one following standards ISO 3448/SAE 80 - 90W/ SAE J 306-81; in particular cases, oils with different viscosities can be used, in this event please contact Z-Gallop Transmission Technology (Su Zhou) co. ltd. The oil viscosity must be chosen as a function of the ambient and working temperature of the gearbox. For gearboxes that have to operate at high ambient temperatures or where there are strong thermal fluctuations, the use of synthetic based oils is recommended.

In gearboxes with vertical assembly and continuous operation, the oil can undergo excessive overheating; in this event an external expansion tank is necessary (this can be supplied by Z-Gallop Transmission Technology (Su Zhou) co. ltd) to enable the oil to expand due to thermal dilation.

	工厂环境			室外环境	
环境温度	-10°C/+30°C	+10°C/ +45°C	-30°C/+60°C	-20°C/+30°C	+10°C/+45°C
润滑油粘度等级	ISO VG150	ISO VG220	ISO VG150-220	SAE 80W/90	SAE 85W/140

5-3 润滑油的更换

齿轮箱在初次运转150小时后必须更换一次润滑油；让后根据齿轮箱的工作情况，在运转2000-4000小时后换油，且至少每年更换一次，为了方便排空齿轮箱中的润滑油，我们建议润滑油在温热的情况下更换；在灌入新油前必须清洗干净齿轮箱内部。不同的润滑油不能混合在一起。特别是矿物油与合成油，在齿轮箱运行一段时间后，必须定期检查润滑部位，如有必要请加满润滑油。

5-3 Oil changes

The oil change must be carried out after the first 150 hours of work, and then after the following 2000 or 4000 hours of operation, depending on how the gearbox is used and at least once a year. To facilitate the emptying of the gearbox, we advise that the oil change is carried out while the gearbox is warm, the internal parts must be washed with suitable liquid before the introduction of new oil. Different oils must not be mixed together; this is particularly true of mineral and synthetic oils. After the gearbox has been operated, the lubricant level must be checked periodically and topping off carried out when necessary.

5-4 润滑油油温

标准齿轮箱推荐运行温度为 -15°C~ + 40°C 。建议齿轮箱的工作温度不超过90°C。

5-4 Temperature

The advised operating temperature of standard gearboxes should be between -15 deg.C. and + 40 deg. C. Suggest gearboxes working temperature not exceeding+90 deg.C.

6.行星减速机结构示意图

6. Planetary gearbox construction chart

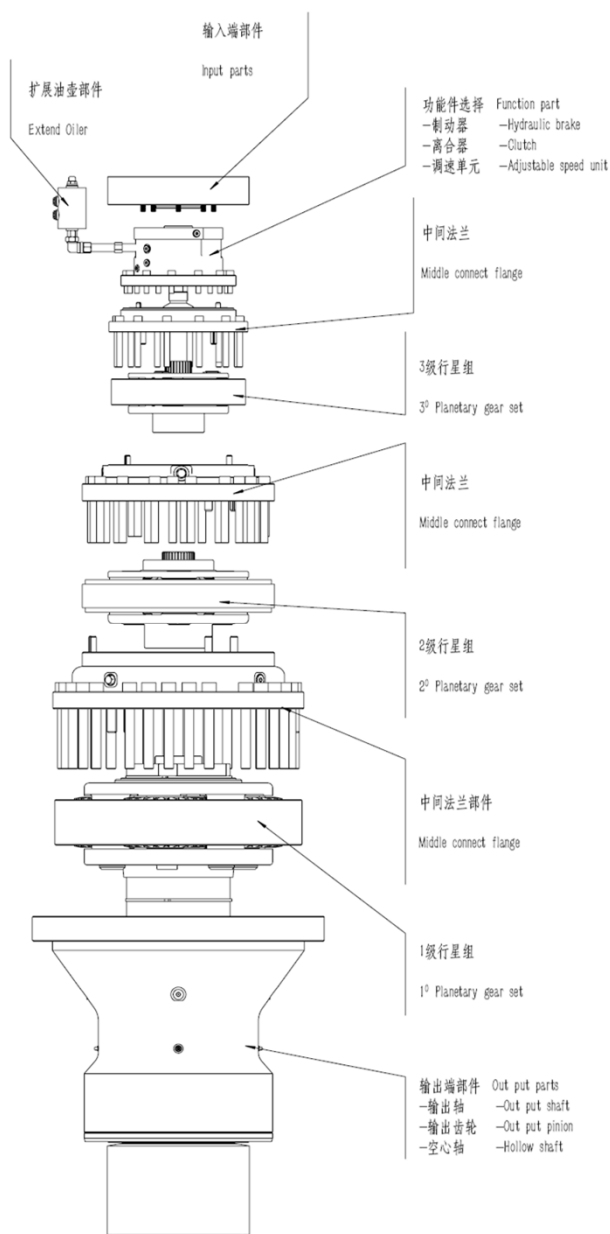

7.减速机旋转方向

7. Direction of rotation

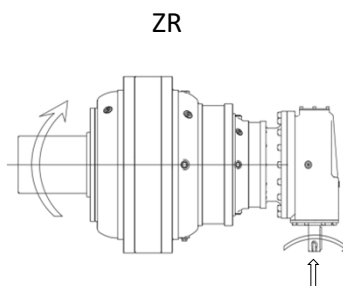
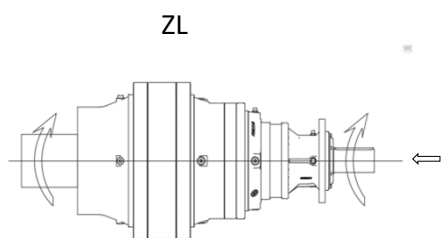

8.产品型号描述 Model description

8-1.订货编号 Order code

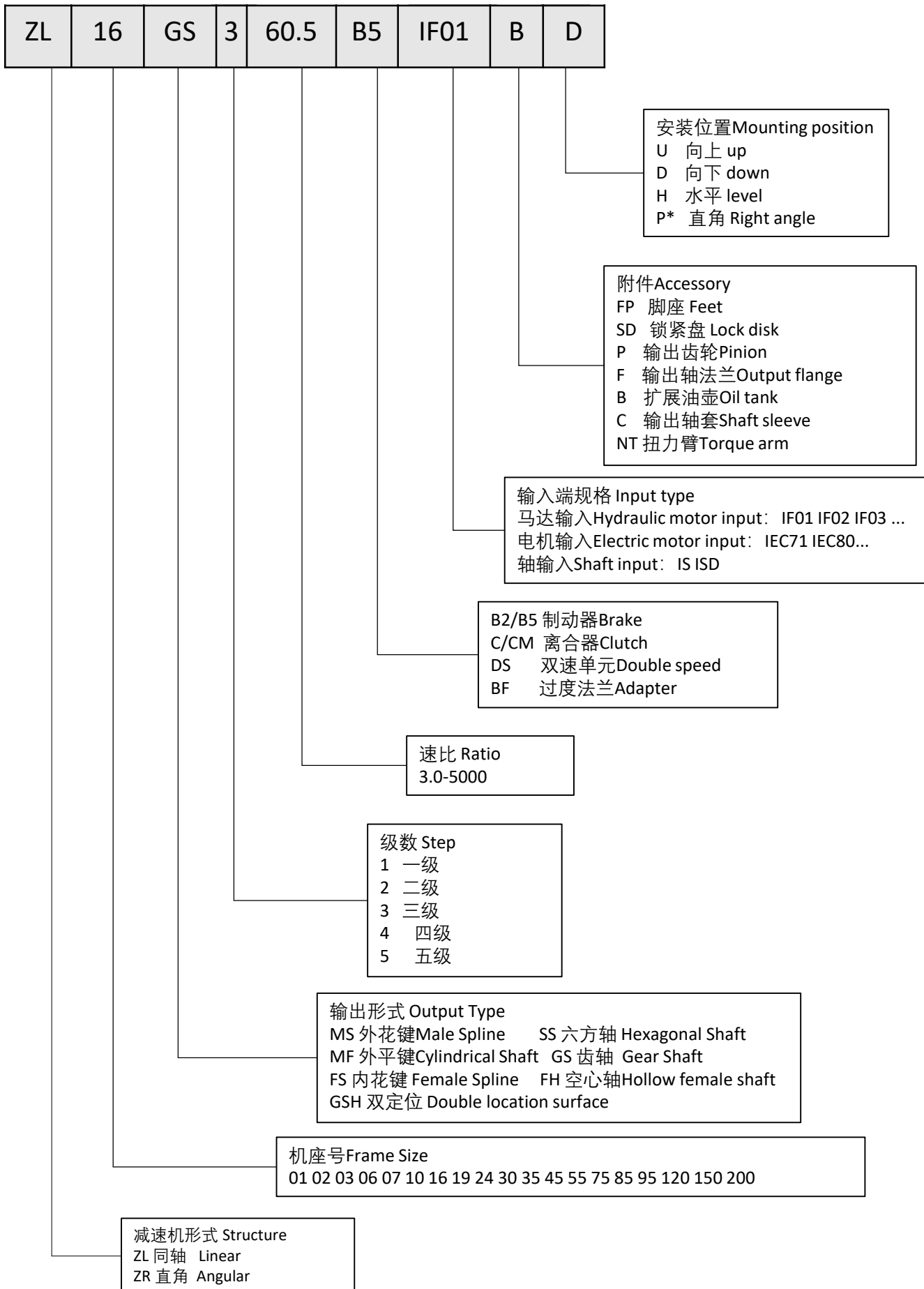

8-2 订货编号说明 Order coder description

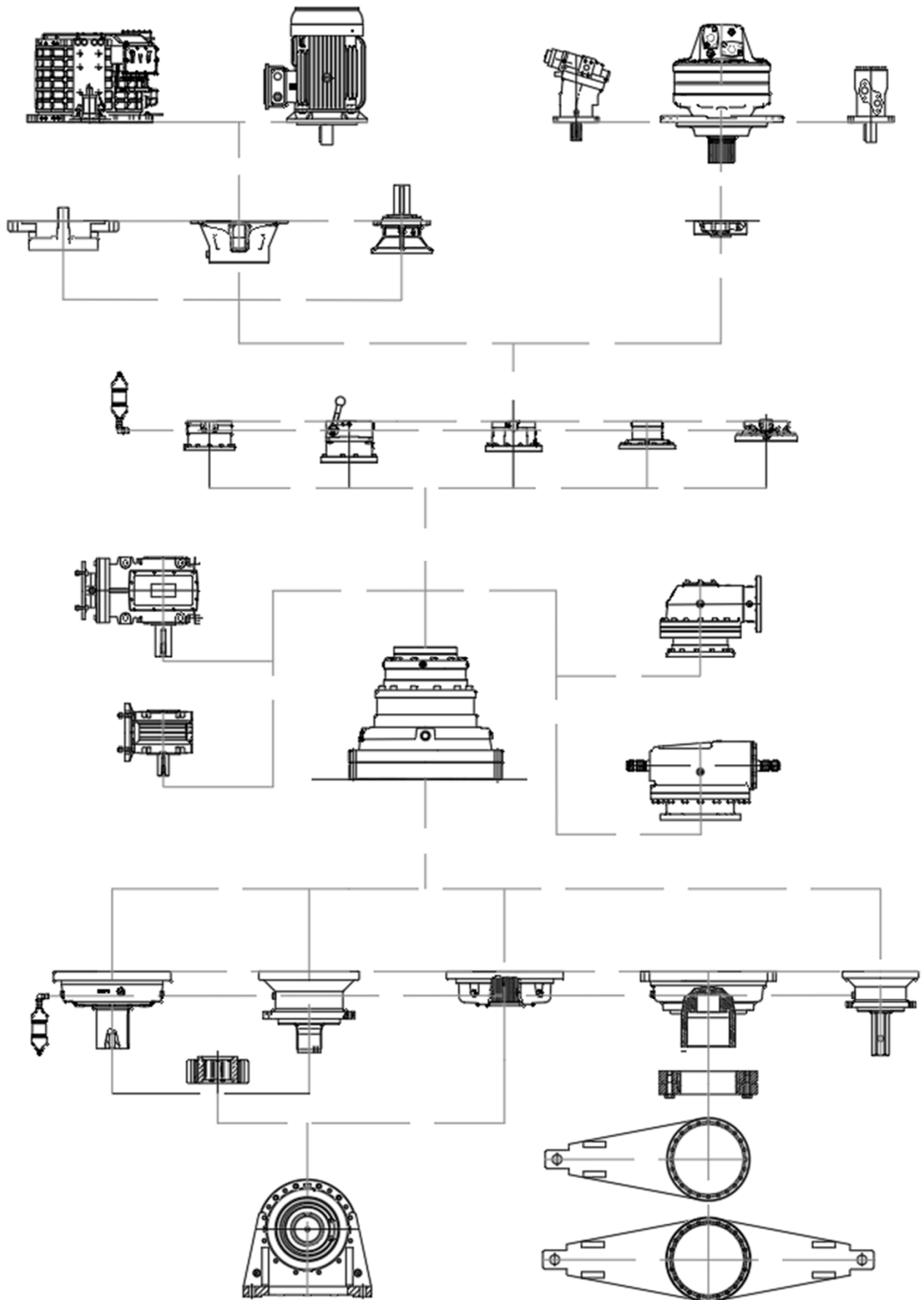

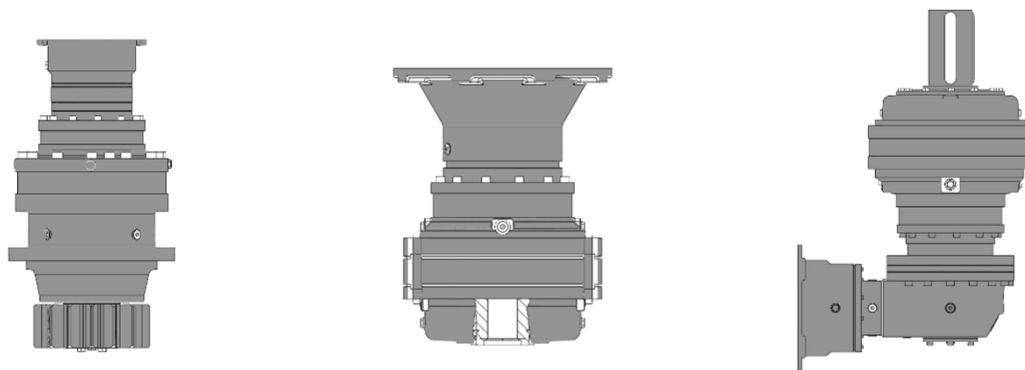

减速机性能参数总表 Gearbox Proformance List									
型号 Type ZL/ZR	速比 范围 Ratio Range	工作扭矩 Working Torque N2*h=100.000 (Tc Nm)	最大扭矩 Max. Torque (Tm Nm)	最大输入转数 Max. Input Speed (n1 max. RPM)					热功率 Thermal Power (Pt KW)
				一级 1stage	二级 2stage	三级 3stage	四级 4stage	五级 5stage	
ZL01 ZR01	3.48-2702	700	1500	5200	5200	5200	5200	-	4.0-22
ZL02 ZR02	3.48-2702	1500	3000	5200	5200	5200	5200	-	4.0-25
ZL03 ZR03	3.6-2011	2400	5500	3200	5000	5000	5000	-	5.0-35
ZL06 ZR06	3.6-2011	4600	11000	3200	5000	5000	5000	-	7.0-37
ZL07 ZR07	4-1240	7100	17000	2500	3200	5000	5000	-	9.0-40
ZL10 ZR10	3.56-2675	10500	26500	2500	3200	5000	4000	-	8.0-45
ZL16 ZR16	3.43-2429	13580	38600	2500	3200	5000	4000	-	9.5-45
ZL19 ZR19	3.83-2130	16500	42000	2000	3200	3200	4000	-	9.5-45
ZL24 ZR24	4-2319	21000	50500	2000	2500	3200	4000	-	15-46
ZL30 ZR30	4-1259	27000	75500	2000	2500	3200	4000	-	15-46
ZL35 ZR35	3.84-2397	34000	85000	2000	2500	3200	4000	-	17-53
ZL45 ZR45	3.84-1745	40500	950000	2000	2500	3200	4000	-	19-55
ZL55 ZR55	4.14-2190	61000	112000	2000	2500	3200	4000	4000	24-74
ZL75 ZR75	4-1502	75000	175000	2000	2000	2500	3200	4000	24-86
ZL85 ZR85	4.05-3509	88000	200000	1500	1500	2000	2500	4000	26-90
ZL95 ZR95	5.07-4800	115000	245000	1500	1500	2000	2500	5000	26-90
ZL120 ZR120	4.09-5440	133000	280000	1500	1500	2000	2500	5000	27-100
ZL150 ZR150	3.83-4256	160000	355000	1500	1500	2000	2500	5000	31-105
ZL200 ZR200	4.4-4504	175000	368000	1500	1500	2000	2500	5000	36-130



ZL系列速比总表 ZL Ratio Information											
级数 stage	ZL01	ZL02	ZL03	ZL06	ZL07	ZL10	ZL16	ZL19	ZL24	ZL30	
一级 1 stage	3.48	3.48	3.60	3.60	4.0	3.56	3.43	3.83	4.00	4.00	
	4.26	4.26	4.25	4.25		4.15	4.09	5.25	5.20		
	5.78	5.78	5.33	5.33		5.10	5.25		6.25		
	7.20	7.20	6.20	6.20		5.82	6.23				
		7.50	7.50			6.86					
二级 2 stage	12.1	12.1	12.5	12.5	14.4	12.8	12.30	13.79	14.2	14.24	
	14.8	14.8	14.8	14.8	17.0	15.1	14.73	16.28	16.6	16.60	
	18.2	18.2	15.3	15.3	21.32	17.7	17.38	18.9	18.5	20.40	
	20.1	20.1	18.1	18.1		18.4	21.80	20.41	21.6	23.28	
	24.6	24.6	20.8	20.8		19.0	25.36	22.31	23.28	27.44	
	25.1	25.1	22.7	22.7		21.7	28.0	23.75	26.52		
	30.7	30.7	24.5	24.5		22.2	30.67	27.98	30.26		
	33.3	33.3	25.4	25.4		25.7	32.55	28.73	35.67		
	41.5	41.5	26.4	26.4		27.2	38.63	32.55	36.38		
	51.8	51.8	30.8	30.8		31.6	46.73	39.37	42.89		
			32.0	32.0			36.1				
			35.8	35.8			38.3				
			38.4	38.4			43.7				
			44.7	44.7			51.5				
		54.0	54.0								
三级 3 stage	42.1	42.1	43.6	43.6	50.11	52.7	51.30	49.64	51.3	51.26	
	51.6	51.6	51.5	51.5	59.16	54.6	60.49	58.60	59.8	59.76	
	63.2	63.2	63.0	63.0	61.34	63.8	62.72	68.04	66.6	70.55	
	69.9	69.9	72.3	72.3	72.42	73.9	65.77	73.49	70.6	75.90	
	77.5	77.5	77.2	77.2	61.34	80.8	74.05	80.33	75.9	83.81	
	85.6	85.6	85.3	85.3	83.09	87.4	80.60	86.76	78.7	86.7	
	87.31	87.31	96.7	96.7	98.09	92.3	93.01	94.83	86.7	88.48	
	104.8	104.8	104.6	104.6	103.82	101.8	100.51	100.74	95.5	98.78	
	106.8	106.8	110.6	110.6	122.57	109.6	109.0	108.81	106.8	106.80	
	116.0	116.0	124.0	124.0	127.80	115.8	113.0	118.93	112.7	116.62	
	130.9	130.9	130.5	130.5	153.72	127.8	125.83	126.57	128.4	124.50	
	141.9	141.9	141.5	141.5	173.10	136.8	139.0	138.34	135.5	144.34	
	144.6	144.6	152.0	152.0	216.30	148.6	146.29	149.15	138.8	153.00	
	177.0	177.0	163.7	163.7		159.5	157.20	153.10	144.3	170.13	
	180.4	180.4	176.5	176.5		185.4	164.55	167.34	151.6	178.40	
	192.0	192.0	190.3	190.3		195.8	177.29	178.10	164.4	205.8	
	221.0	221.0	207.1	207.1		211.3	190.90	203.93	187.6		
	239.7	239.7	221.5	221.5		227.7	202.29	215.44	205.8		
	299.0	299.0	258.0	258.0		252.3	218.28	236.78	225.5		
	373.0	373.0	276.0	276.0		275.4	234.7	249.63	239.1		
		321.0	321.0		314.5	278.50	279.53	267.5			
		389.0	389.0		371.0	336.90	295.31	321.6			
四级 4 stage	243.1	243.1	252.0	252.0	205.88	232.6	210.6	255.75	178.4	178.40	
	269.6	269.6	297.5	297.5	213.48	245.83	228.89	279.53	210.6	205.80	
	303.4	303.4	336.6	336.6	252.02	261.5	257.7	294.70	218.4	218.38	
	329.38	329.38	364.2	364.2	261.33	281.3	296.2	313.07	231.9	245.51	
	364.9	364.9	418.5	418.5	289.15	299.6	315.5	330.00	245.51	264.13	
	403.0	403.0	454.3	454.3	308.51	315.6	338.9	350.56	254.6	291.65	
	447.0	447.0	479.3	479.3	316.06	344.3	362.5	359.87	278.75	312.85	
	455.40	455.40	494.1	494.1	341.35	369.3	395.6	378.65	301.7	323.33	
	493.8	493.8	522.1	522.1	363.31	395.8	438.5	392.59	329.1	344.31	
	557.9	557.9	556.1	556.1	386.91	421.44	480.5	413.86	345.4	378.38	
	616.0	616.0	579.8	579.8	417.86	444.9	532.6	440.45	383.61	407.78	
	627.8	627.8	616.4	616.4	428.10	505.5	590.7	481.41	400.3	431.80	
	669.52	669.52	697.4	697.4	444.74	582.8	631.4	506.62	423.75	463.20	
	755.0	755.0	768.8	768.8	479.42	645.6	688.9	539.17	449.0	496.80	
	818.6	818.6	867.1	867.1	522.15	717.9	724.4	579.14	505.2	528.59	
	838.28	838.28	941.60	941.60	534.94	769.4	778.9	603.75	528.59	570.97	
	942.2	942.2	1023.7	1023.7	565.98	855.5	817.6	652.22	588.9	604.26	
	1021.6	1021.6	1180.3	1180.3	602.39	916.9	884.6	704.41	623.05	628.47	
	1108.0	1108.0	1277.0	1277.0	654.84	1029.2	939.8	784.50	677.0	674.06	
	1257.0	1257.0	1356.8	1356.8	707.23	1149.9	988.0	844.87	784.8	717.20	
	1304.28	1304.28	1488.26	1488.26	737.41	1285.8	1109.4	912.54	897.6	783.96	
	1383.0	1383.0	1660.89	1660.89	752.72	1413.1	1290.4	965.57	1001.0	834.26	
	1591.2	1591.2	1803.43	1803.43	883.73	1594.0	1356.48	1075.35	1203.2	884.34	
	1725.4	1725.4	1997.71	1997.71	921.44	1718.9	1435.1	1206.55	1397.9	911.92	
	2153.4	2153.4	2249.61	2249.61	998.79	1900.7	1609.7	1408.60	1626.0	983.34	
	2687.0	2687.0	2323.79	2323.79	1108.30	2211.0	1947.2	1553.30	1916.6	1040.66	
2702.13	2702.13	2811.04	2811.04	1248.05	2674.6	2429.0	2129.20	2318.5	1258.87		



ZL系列速比总表 ZL Ratio Information									
级数 stage	ZL35	ZL45	ZL55	ZL75	ZL85	ZL95	ZL120	ZL150	ZL200
一级 1 stage	3.84	3.84	4.14	4.0	4.05	5.07	4.09	3.83	4.4
	4.74	5.18	5.40	4.67				4.4	
	5.44		6.50						
	6.46								
二级 2 stage	13.7	15.71	14.20	16.00	16.20	20.28	15.71	14.71	18.22
	16.9	20.16	16.91	18.68	21.06	26.36	19.39	16.90	23.76
	19.7	23.92	21.72	20.80	25.31	31.69	22.25	19.84	28.60
	22.6	27.20	22.15	24.28			26.42	22.79	
	24.17	32.27	25.86	25.00					
	26.3		26.69	28.19					
	27.7		28.42						
	31.66		33.60						
	32.5		34.19						
	37.3		40.55						
44.3									
三级 3 stage	49.2	56.54	61.0	56.95	57.67	72.20	55.91	60.15	69.77
	58.1	66.75	72.0	66.40	67.23	84.16	65.18	69.10	91.00
	67.7	72.58	79.51	74.05	74.97	93.86	69.01	77.21	95.63
	72.9	76.27	92.85	77.52	82.62	103.43	79.21	88.70	109.54
	80.46	83.71	95.7	81.60	87.40	109.41	91.41	93.22	124.74
	82.3	86.12	102.1	86.45	90.11	112.81	98.87	105.26	150.15
	84.94	90.04	105.0	89.00	94.28	118.03	109.65	123.60	
	89.9	97.90	113.0	93.12	105.05	131.50	129.49	141.99	
	96.5	101.90	120.5	100.78	107.41	134.46	134.75		
	99.88	112.92	127.0	108.72	122.57	139.12	152.63		
	113.98	117.79	136.9	121.06	129.09	153.44	181.25		
	120.3	124.99	141.7	128.14	147.32	161.61			
	120.3	131.35	151.11	141.33		180.86			
	128.8	137.15	159.9	145.50		184.42			
	140.0	144.95	164.8	148.86		217.38			
	151.1	158.90	172.1	166.59					
	167.6	168.61	181.88	171.50					
	181.3	172.01	193.4	200.23					
	200.4	179.42	199.4						
	231.4	200.08	211.6						
247.1	203.96	251.1							
332.4	242.04	303.70							
四级 4 stage	247.52	196.76	250.4	205.06	207.62	259.91	248.46	216.55	251.16
	274.76	203.96	272.3	239.40	242.02	302.98	285.15	248.78	296.51
	290.98	232.29	306.6	266.57	269.90	337.88	293.32	277.96	327.60
	300.34	240.86	333.3	282.63	285.73	357.69	332.41	293.12	344.28
	313.09	252.56	355.2	293.76	297.43	372.34	341.93	319.33	371.86
	330.54	265.42	381.5	303.60	314.64	398.89	367.86	335.59	386.75
	340.15	284.35	403.1	314.70	324.40	424.91	392.42	344.86	394.34
	359.27	299.71	427.5	335.23	339.42	439.57	408.50	372.96	406.44
	370.73	313.34	452.3	353.15	357.56	448.58	428.82	396.18	432.56
	391.56	338.86	481.3	367.42	371.45	465.00	466.00	411.54	449.06
	410.33	356.61	513.3	381.89	386.66	479.43	482.26	432.49	465.54
	420.90	385.81	542.5	395.14	400.70	500.25	501.34	451.14	485.03
	440.42	402.21	583.34	413.19	432.54	521.80	517.62	472.79	509.73
	468.36	434.97	606.8	435.80	464.74	541.27	549.48	503.09	523.25
	497.26	457.11	643.71	459.00	480.30	571.44	565.22	525.29	540.54
	509.26	477.29	681.22	474.37	502.53	591.26	594.06	555.16	564.20
	549.00	497.79	700.02	498.76	520.91	601.23	613.00	579.10	592.93
	588.71	523.27	725.9	523.80	548.65	631.22	653.53	608.57	638.14
	608.72	552.96	778.90	555.36	584.56	663.92	679.82	637.78	664.86
	643.62	586.76	814.6	590.66	619.65	699.41	699.55	645.77	679.14
	704.75	603.56	848.75	624.83	655.49	741.51	718.21	687.19	682.51
	755.94	644.11	885.75	645.23	688.07	783.79	741.54	699.14	717.26
	800.99	680.84	905.8	667.50	707.13	820.58	770.32	741.87	773.39
	886.42	702.79	957.43	708.00	759.93	846.06	802.85	766.32	800.30
	999.00	774.73	994.8	755.84	785.93	885.22	824.55	789.47	821.53
	1141.91	833.32	1090.3	795.60	805.55	923.85	851.04	880.36	930.93
	1307.23	901.19	1152.46	823.20	913.38	982.97	946.32	926.99	1126.13
	1453.55	988.88	1222.9	876.26	968.20	1043.41	997.44	1064.96	
	1500.38	1069.41	1394.7	956.25	1104.89	1150.79	1123.75		
	1781.66	1178.90	1503.9	1091.25		1212.05	1359.38		
1921.08	1442.60	1755.5	1249.41		1383.16				
2396.45	1745.08	2189.8	1501.70		1603.32				

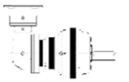

ZR系列速比总表 ZR Ratio Information							
级数 stage	ZR03	ZR06	ZR10	ZR16	ZR19	ZR24	ZR30
二级 1 stage	7.96	7.96	7.87	14.19	13.29	13.88	
	9.39	9.39	9.17	18.22	18.22	18.04	
	11.78	11.78	11.27	21.62		21.69	
	13.70	13.7	15.16				
	16.58	16.58					
三级 2 stage	27.69	27.69	28.32	32.54	43.43	49.41	44.86
	33.89	33.89	33.43	38.42	51.27	57.60	52.29
	40.99	40.99	40.58	41.77	64.30	64.24	64.26
	47.68	47.68	46.30	49.56	70.28	70.79	73.33
	57.36	57.36	54.58	56.04	88.15	77.21	86.44
	67.97	67.97	60.07	61.84	102.53	92.02	
	79.06	79.06	68.78	71.94	124.03	105.02	
	95.64	95.64	79.74	85.36		110.61	
	98.79	98.79	84.53			126.22	
	119.51	119.51	96.47			148.78	
		113.70					
四级 3 stage	113.75	113.75	98.56	113.26	109.70	133.75	113.29
	139.24	139.24	116.36	133.69	129.50	147.28	133.75
	144.38	144.38	135.65	145.36	150.37	162.30	155.92
	159.75	159.75	145.93	163.65	163.41	177.02	167.74
	174.63	174.63	163.71	172.49	177.52	195.12	191.61
	199.62	199.62	178.64	188.08	191.74	208.99	195.54
	213.77	213.77	197.88	203.63	209.57	227.45	218.31
	230.87	230.87	209.06	215.21	222.63	236.03	227.45
	245.72	245.72	225.30	235.92	240.46	249.09	236.03
	275.13	275.13	238.57	249.28	279.71	257.73	257.73
	295.55	295.55	251.92	263.44	305.73	279.52	279.53
	312.70	312.70	274.48	285.02	329.61	295.39	318.98
	330.98	330.98	297.69	301.45	369.83	306.84	338.13
	343.79	343.79	315.96	338.22	383.42	323.22	375.98
	361.80	361.80	333.85	359.35	463.81	341.11	385.87
	392.16	392.16	345.37	370.70	539.52	355.40	454.82
	415.88	415.88	372.42	391.84	652.64	375.99	
	456.18	456.18	400.42	415.79		385.87	
	490.04	490.04	425.44	439.89		402.70	
	509.09	509.09	464.56			414.68	
551.83	551.83	494.28	493.40		436.75		
570.00	570.0	543.30	529.11		488.78		
612.34	612.34	582.61	596.86		505.04		
689.55	689.55	657.21	615.47		587.47		
712.29	712.29	695.52	744.52		602.92		
五级 4 stage				466.22	381.75	459.60	394.26
				505.84	450.67	542.59	465.44
				583.45	565.20	597.48	482.26
				619.23	657.45	616.03	542.59
				678.68	691.88	664.20	583.73
				714.22	729.30	691.41	644.55
				772.70	776.16	718.13	691.41
				816.46	804.81	754.11	714.56
				874.30	867.63	791.54	760.93
				916.78	901.21	831.20	791.54
				1004.99	973.56	882.52	821.38
				1087.92	1063.93	912.93	836.24
				1186.26	1106.33	954.30	896.24
				1218.34	1209.22	1005.48	930.01
				1290.04	1286.91	1125.82	964.33
				1356.07	1318.65	1236.89	1005.48
				1406.12	1387.46	1330.77	1107.49
				1520.07	1441.42	1487.10	1190.76
				1653.05	1516.50	1582.26	1263.84
				1747.30	1605.15	1701.13	1381.49
			1899.43	1733.73	1838.58	1440.43	
			2138.94	1807.55	1983.79	1590.33	
			2399.09	1901.87	2131.92	1732.55	
			2621.90	2016.72	2578.93	1977.14	
			3058.23	2298.34	3616.72	2299.86	
			4437.55	3432.80	4347.02	2710.84	

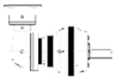

ZR系列速比总表 ZR Ratio Information						
级数 stage	ZR35	ZR45	ZR55	ZR75	ZR85	ZR95
三级 3 stage	43.06	49.47	58.76	55.52	56.21	70.37
	53.15	63.50	76.63	64.82	73.08	91.48
	61.96	75.36	89.50	72.18	87.83	109.96
	70.40	85.66	98.37	86.75		
	82.98	101.66	116.74	101.28		
	99.73		140.52			
	117.55					
	139.59					
四级 4 stage	108.76	124.95	134.72	179.42	181.67	227.42
	128.40	147.51	159.04	209.16	211.77	265.11
	149.68	160.39	172.92	233.25	236.17	295.65
	158.49	185.00	199.45	244.19	260.25	325.80
	182.97	198.99	211.51	257.04	275.30	344.64
	198.77	216.36	225.55	271.91	283.85	355.34
	212.05	237.47	242.25	293.33	297.00	371.79
	228.12	249.56	256.02	300.10	330.90	414.24
	247.42	256.75	271.50	317.45	338.33	423.54
	260.58	276.23	280.66	327.31	386.09	438.23
	284.75	290.29	297.81	342.46	406.65	483.33
	299.12	303.34	315.98	381.33	464.05	509.06
	315.11	327.80	333.94	390.12		569.70
	333.90	351.16	353.40	403.66		580.93
	352.57	372.63	366.08	445.20		684.74
	370.43	380.13	388.45	458.33		
	388.08	396.53	401.97	468.90		
	416.23	442.18	427.51	524.75		
	436.63	450.76	440.65	540.23		
	445.54	534.90	467.58	630.71		
459.86		477.00				
511.16		554.86				
546.08		565.62				
607.21						
734.53						
五级 5 stage	463.33	434.84	557.62	589.13	458.84	574.40
	520.88	513.35	601.77	616.77	534.88	669.59
	571.92	558.17	671.20	649.21	541.69	746.72
	618.55	586.58	694.10	670.95	596.49	790.49
	640.12	628.41	714.11	687.80	631.46	822.87
	669.30	658.95	736.06	708.08	679.34	850.43
	691.71	683.27	778.66	740.86	704.19	870.47
	730.49	718.05	807.40	766.43	750.12	897.50
	787.08	748.89	843.04	783.33	790.22	939.04
	806.35	781.95	869.66	801.79	820.89	971.45
	865.14	806.64	883.71	825.44	846.38	991.37
	900.28	847.70	905.35	864.96	885.56	1069.74
	942.72	888.89	931.44	894.80	921.19	1106.85
	990.94	905.91	960.85	913.15	955.91	1218.31
	1102.06	927.07	999.50	944.11	986.65	1285.74
	1248.51	961.29	1053.27	985.34	1029.50	1328.79
	1333.29	1010.22	1099.62	1014.39	1132.06	1417.17
	1497.65	1100.12	1156.58	1122.19	1212.51	1499.14
	1600.26	1215.30	1268.68	1219.48	1369.43	1545.69
	1769.97	1379.91	1398.85	1340.20	1471.68	1638.75
	1904.44	1484.02	1503.71	1458.84	1562.76	1801.86
	2113.10	1619.37	1800.33	1593.00	1679.44	2041.71
	2342.91	1841.64	2023.54	1719.89	1780.25	2478.10
	2523.69	2029.71	2664.36	1993.64	2031.58	2678.49
3575.23	2291.93	3269.29	2282.59	2139.73	2997.71	
4459.76	3188.14	4020.41	2815.62	2441.81	3603.01	



FS

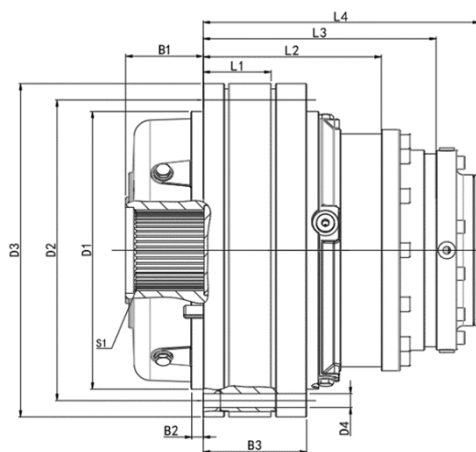

尺寸 Dimensions (mm)												
型号Type	S1	B1	B2	B3	D1	D2	D3	D4	L1	L2	L3	L4
ZL01 ZR01	A40X36 DIN5482	5	5	70	110	165	187	8* ϕ 10.5	59	102	145	190
ZL02 ZR02	A40X36 DIN5482	5	5	81	110	165	187	8* ϕ 10.5	70	114	157	200
ZL03 ZR03	A58X53 DIN5482	51	10	62	200	222	244	12* ϕ 10.5	39.5	92	135	178
ZL06 ZR06	A58X53 DIN5482	51	10	80	200	222	244	12* ϕ 10.5	58	122	165	208
ZL07 ZR07	A58X53 DIN5482	51	10	80	200	222	244	12* ϕ 10.5	58	122	165	208
ZL10 ZR10	A80X74 DIN5482	57	10	100	240	265	295	12* ϕ 13	85	170	235	278
ZL16 ZR16	A80X74 A88X82 DIN5482	83	15	104	278	314	350	12* ϕ 17	77.5	170.5	235	278
ZL19 ZR19	A80X74 A88X82 DIN5482	83	15	103.5	278	314	350	12* ϕ 17	77.5	170.5	229	281.5
ZL24 ZR24	A100X94 DIN5482	95	15	126	240	370	409	15* ϕ 17	93	204	271	323.5
ZL30 ZR30	A100X94 DIN5482	95	15	126	240	370	409	15* ϕ 17	93	221	306	370.5
ZL35 ZR35	N120X3XH9 DIN5480	109.5	15	120	390	424	452	18* ϕ 17	85	277	362	426.5
ZL45 ZR45	N120X3XH9 N140X5XH9 DIN5480	109.5	15	120	390	424	452	24* ϕ 19	85	326	419	483.5
ZL55 ZR55	N140X5XH9 DIN5480	100	15	178.5	410	445	490	24* ϕ 19	136.5	326	398	456.5
ZL75 ZR75	N140X5XH9 DIN5480	100	15	181.5	410	445	490	24* ϕ 19	136.5	390.5	581.5	603.5
ZL85 ZR85	N160X5X9H DIN5480	149	20	155	460	510	552	28* ϕ 26	126	302	436	515
ZL95 ZR95	N160X5X9H DIN5480	149	20	155	460	510	552	28* ϕ 26	126	302	436	515
ZL120 ZR120	N160X5X9H DIN5480	152	20	230	515	560	610	36* ϕ 25	170	410	522	590
ZL150 ZR150	N160X5X9H DIN5480	152	20	230	515	560	610	36* ϕ 25	170	430	620	705
ZL200 ZR200	N220X5X9H	185	20	193	600	660	710	36* ϕ 28	164	460	627	722

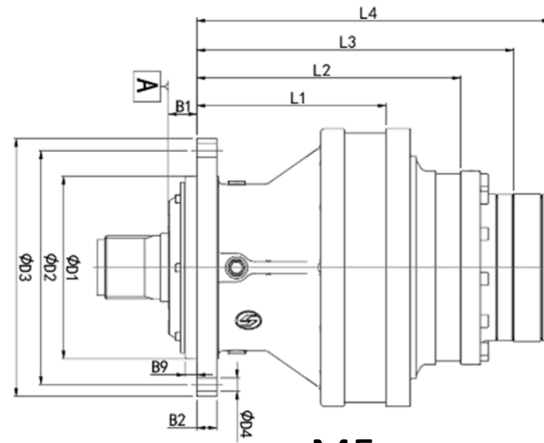
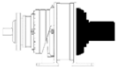

MS

MF

SS

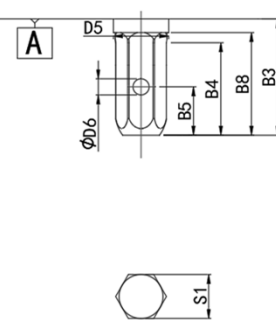
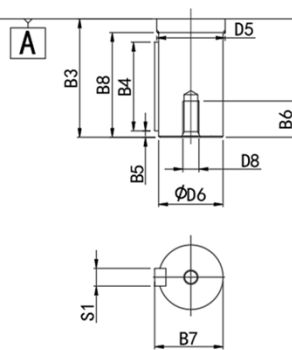
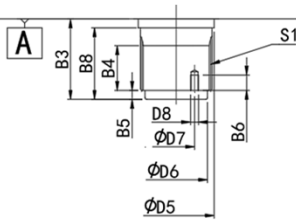

尺寸 Dimensions (mm)																							
型号Type	S1	B1	B2	B3	B4	B5	B6	B7	B8	B9	D1	D2	D3	D4	D5	D6	D7	D8	L1	L2	L3	L4	
ZL01	MS	B40X36 DIN5482	5	12	55	30	5	13	-	48	5	110	165	185	8*Φ 11	46	35	24	3*M 6	95	138	181	224
	MF	12*8*70			87	70	6	30	45	82							42	-	M16				
	SS	50			137	112	54	-	-	132							18	-	-				
ZL02	MS	B40X36 DIN5482	5	12	55	30	5	13	-	50	5	110	165	185	8*Φ 11	46	35	24	3*M 6	107	150	193	236
	MF	12*8*70			87	70	6	30	45	82							42	-	M16				
	SS	50			137	112	54	-	-	132							18	-	-				
ZL03	MS	B58X53 DIN5482	15.5	18	69	37	8	20	-	58	12.5	150	195	222	10* Φ13	60	50	32	3*M 10	134	187	230	273
	MF	18*11*90			110	90	8	30	64	105							60	-	M16				
	SS	50			143	128	54	-	-	140													
ZL06 ZL07	MS	B58X53 DIN5482	15.5	16	69	37	8	20	-	58	15	150	195	222	10* Φ13	60	50	32	3*M 10	151	216	259	302
	MF	18*11*90			110	90	8	30	64	105							60	-	M20				
	SS	70			185	130	65	-	-	190							22	-	-				
ZL10	MS	B80X74 DIN5482	36	25	90	50	10	25	-	80	15	230	295	325	10* Φ17	85	70	45	3*M 10	237	321	386	429
	MF	25*14*160			175	160	5	50	95	170							90	-	M24				
ZL16	MS	B80X74 DIN5482	36	25	90	50	10	25	-	80	15	230	295	325	10* Φ17	85	70	45	3*M 10	240	333	398	441
	MF	25*14*160			175	160	5	50	95	170							90	-	M24				
ZL19	MS	B80X74 DIN5482	36	25	90	50	10	25	-	80	15	230	295	325	10* Φ17	85	70	45	3*M 10	240	333	398	441
	MF	25*14*160			175	160	5	50	95	170							90	-	M24				
ZL24	MS	B100X94 DIN5482	68	25	105	85	10	30	-	100	20	340	370	410	20* Φ21	105	85	52	3*M 12	200	311	377	430
	MF	28*16*200			215	200	5	50	116	210							110	-	M24				
ZL30	MS	B100X94 DIN5482	68	25	105	85	10	30	-	100	20	340	370	410	20* Φ21	105	85	52	3*M 12	200	311	400	463
	MF	28*16*200			215	200	5	50	116	210							110	-	M24				

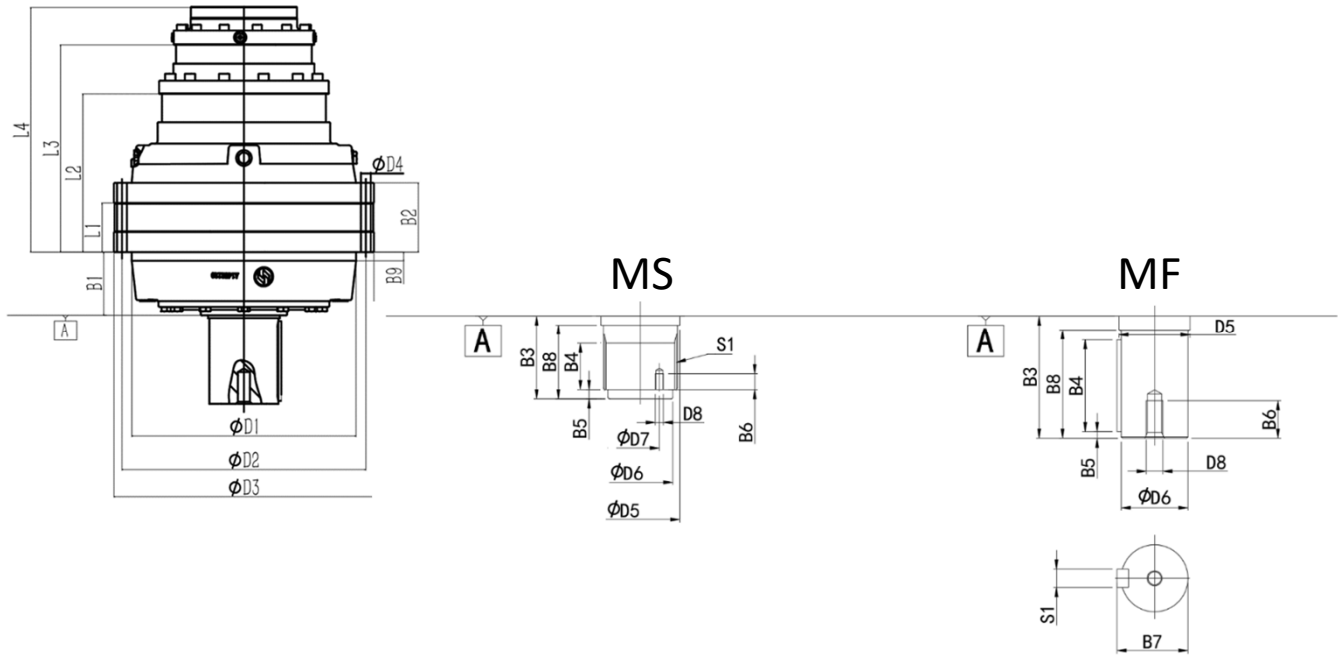
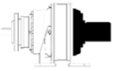

尺寸 Dimensions (mm)																							
型号Type	S1	B1	B2	B3	B4	B5	B6	B7	B8	B9	D1	D2	D3	D4	D5	D6	D7	D8	L1	L2	L3	L4	
ZL35 ZR35	MS	W120X3X8f DIN5480	109	120	136	95	15	30	-	126	15	390	424	452	18* Φ17	150	90	50	3*M 16	85	277	362	427
	MF	32*18*200 n ² -120°			215	200	5	50	127	210							120	-	M24				
ZL45 ZR45	MS	W120X3X8f DIN5480	109	120	136	95	15	30	-	126	15	390	424	452	18* Φ17	150	90	50	3*M 16	85	285	370	435
	MF	32*18*200 n ² -120°			215	200	5	50	127	210							120	-	M24				
ZL55 ZR55	MS	W150X5X8f DIN5480	126	158	150	107	12	35	-	136	15	410	445	490	24* Φ19	155	125	80	3*M 16	116	285	378	443
	MF	40*22*210 n ² -120°			235	210	10	50	169	230							160	-	M24				
ZL75 ZR75	MS	W150X5X8f DIN5480	126	158	150	107	12	35	-	136	15	410	445	490	24* Φ19	155	125	80	3*M 16	116	295	410	480
	MF	40*22*210 n ² -120°			235	210	10	50	169	230							160	-	M24				
ZL85 ZR85	MS	W170x5x8f DIN5480	163	158	170	110	15	35	-	150	20	460	510	552	28* Φ26	175	140	110	3*M 16	128	312	442	507
	MF	45*220 n ² -120°			245	220	10	35	180	240							170	-	M24				
ZL95 ZR95	MS	W170x5x8f DIN5480	163	158	170	110	15	35	-	150	20	460	510	552	30* Φ21	175	140	110	3*M 16	128	312	442	507
	MF	45*220 n ² -120°			245	220	10	35	180	240							170	-	M24				
ZL120 ZR120	MS	W170x5x8f DIN5480	140	230	165	110	15	35	-	150	20	515	560	610	36* Φ26	185	150	110	4*M 16	161	410	538	623
	MF	45*220 n ² -120°			245	220	10	35	190	240							180	-	2*M 20				
ZL150 ZR150	MS	W170x5x8f DIN5480	140	230	165	110	15	35	-	150	20	515	560	610	36* Φ26	185	150	110	4*M 16	161	430	670	765
	MF	45*220 n ² -120°			245	220	10	35	190	240							180	-	2*M 20				
ZL200 ZR200	MS	W220X5X8f DIN5480	180	195	210	140	20	50	-	187	22	600	660	710	36* Φ28	220	200	150	4*M 20	138	443	612	705
	MF	50*280 n ² -120°			305	280	10	50	241	300							230	-	2*M 24				

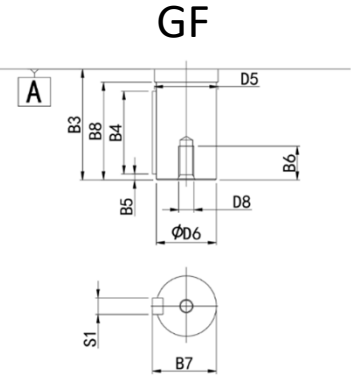
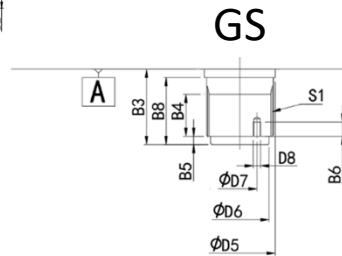
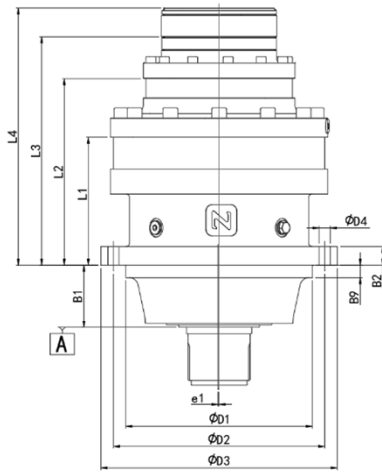

尺寸 Dimensions (mm)																							
型号Type	S1	B1	B2	B3	B4	B5	B6	B7	B8	B9	D1	D2	D3	D4	D5	D6	D7	D8	L1	L2	L3	L4	
ZL06 ZL07	GS	B58X53 DIN5482	40	20	69	37	8	20	-	58	5	175	245	272	18	60	50	32	M10	170	230	283	290
	GF	18*11*90			110	90	8	30	64	105							60	-	M20				
ZL10	GS	B80X74 DIN5482	67	22	90	50	10	25	-	80	5	216	260	290	18	85	70	45	M10	200	285	338	345
	GF	25*14*160			175	160	5	50	95	170							90	-	M24				
ZL16	GS	B80X74 DIN5482	95	25	90	50	10	25	-	80	20	300	340	380	24* Phi18	85	70	45	M10	206	301	366	410
	GF	25*14*160			175	160	5	50	95	170							90	-	M24				
ZL19	GS	B80X74 DIN5482	95	25	90	50	10	25	-	80	20	300	340	380	24* Phi18	85	70	45	M10	206	301	372	416
	GF	25*14*160			175	160	5	50	95	170							90	-	M24				
ZL24	GS	B100X94 DIN5482	68	25	105	85	10	30	-	100	20	340	370	410	20* Phi21	105	85	52	M12	200	311	377	430
	GF	28*16*200			215	200	5	50	116	210							110	-	M24				
ZL30	GS	B100X94 DIN5482	68	25	105	85	10	30	-	100	20	340	370	410	20* Phi21	105	85	52	M12	200	311	400	463
	GF	28*16*200			215	200	5	50	116	210							110	-	M24				
ZL35	GS	W120X3X8f DIN5480	103	30	136	95	15	30	-	126	15	380	424	465	22	150	90	50	M16	290	479	564	630
	GF	32*18*200 n ² -120°			215	200	5	50	127	210							120	-	M24				
ZL45	GS	W120X3X8f DIN5480	103	30	136	95	15	30	-	126	15	380	424	465	22	150	90	50	M16	290	487	577	642
	GF	32*18*200 n ² -120°			215	200	5	50	127	210							120	-	M24				
ZL55	GS	W150X5X8f DIN5480	110	30	150	107	12	35	-	136	15	410	445	490	22	155	125	80	M16	345	513	606	665
	GF	40*22*210 n ² -120°			235	210	10	50	169	230							160	-	M24				
ZL75	GS	W150X5X8f DIN5480	110	30	150	107	12	35	-	136	15	410	445	490	22	155	125	80	M16	345	528	635	715
	GF	40*22*210 n ² -120°			235	210	10	50	169	230							160	-	M24				

B5/B6

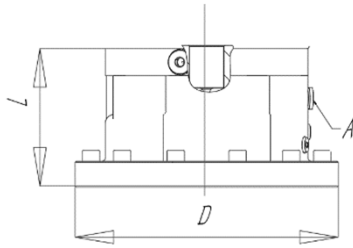

B1/B2

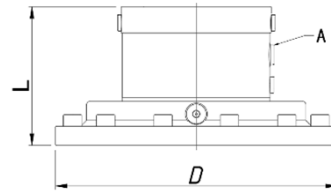

多片式液压制动器性能表 Hydraulic Brake Performance List

制动器型号 Brake type	B102	B202	B106	B206	B506	B606	B510	B610
制动器开启压力孔 A	G1/4"	G1/4"	G1/4"	G1/4"	G1/4"	G1/4"	G1/4"	G1/4"
制动扭矩 Torque NM	250	250	600	600	600	600	1000	1000
开启压力 Open Pressure Bar	18	18	25	25	30	30	30	30
最大转数 Max. Speed Rpm	1500	1500	1500	1500	3000	3000	3000	3000
适配单元 Adapter unit	ZL01 ZL02	ZL03 ZL06 ZL07	ZL01 ZL02	ZL03 ZL06 ZL07	ZL01 ZL02	ZL03 ZL06 ZL07	ZL01 ZL02	ZL03 ZL06 ZL07
D mm	188	245	188	245	188	245	188	245
L mm	110	120	110	120	118	128	118	128
重量 Weight Kg								

DS

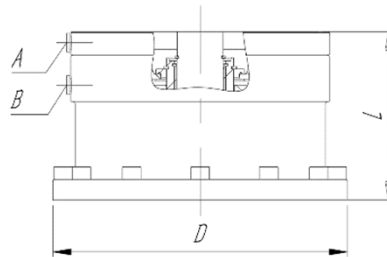

可调速单元性能表 Performance List	
型号	DS
低速开启压力孔 A	M10*1.0
高速开启压力孔 B	M10*1.0
低速传递扭矩 Torque	2500 nm
高速传动扭矩	1400 nm
低速开启压力 Low speed Open Pressure	30
高速开启压力 High speed Open Pressure	45
低速最大转数 Low speed Input Max. speed	3000 rpm
高速最大转数 High speed Input Max. speed	1500 rpm
适配单元 Adapter unit	ZL03 ZL06
L mm	163
D mm	285
重量 Weight Kg	50

CM3

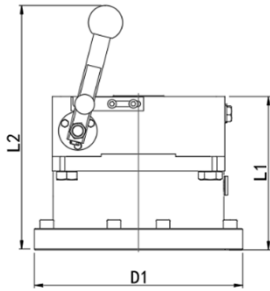

CM3S

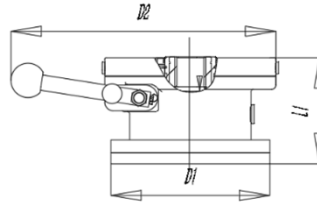

机械式离合器性能表 Performance List		
型号 Brake type	CM3	CM3S
适配单元 Adapter unit	ZL03 ZL06 ZL07	ZL01 ZL02
L1	179	112
L2	286	-
D1 mm	245	186
D2 mm	-	310
重量 Weight Kg		

IS

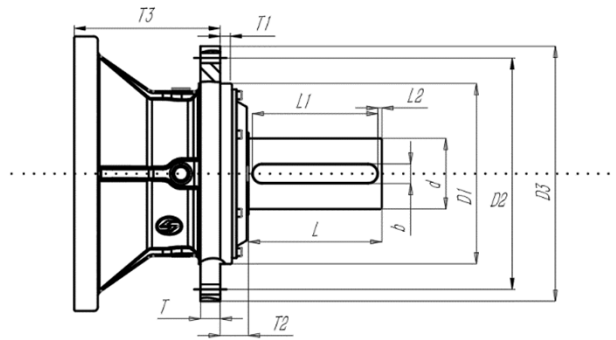

轴输入参数表 单位MM				
型号	IS02	IS03	IS10	IS16
适配单元 Adapter unit	ZL01 ZL02	ZL03 ZL06 ZL07	ZL10	ZL16 ZL19
D1	110	150	230	230
D2	165	195	295	295
D3	185	222	325	325
d	42	60	90	90
b	8	11	14	14
L	82	105	170	170
L1	70	90	160	160
L2	6	8	5	5
T	12	16	25	25
T1	6.5	12.5	15	15
T2	11.5	16	36	36
T3	102	114	183	186
重量 Weight Kg				

IEC电机法兰标准 50HZ
IEC electric motor 50HZ

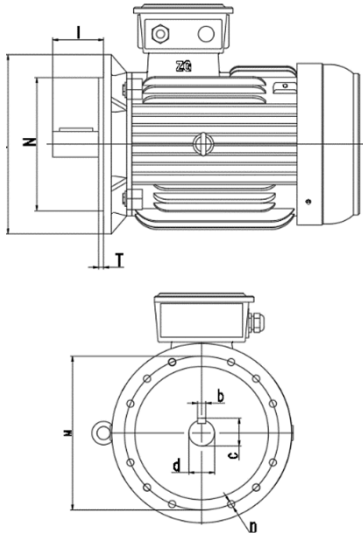

安装尺寸 Mounting Dimensions									
机座号	M	N	P	T	n	d	b	c	l
80	165	130	200	3.5	4*12	19	6	15.5	40
90	165	130	200	3.5	4*12	24	8	20	50
100	215	180	250	4	4*15	28	8	24	60
112	215	180	250	4	4*15	28	8	24	60
132	265	230	300	4	4*15	38	10	33	80
160	300	250	350	5	4*19	42	12	37	110
180	300	250	350	5	4*19	48	14	42.5	110
200	350	300	400	5	4*19	55	16	49	110
225 (4.6.8)	400	350	450	5	8*19	60	18	53	140
250 (4.6.8)	500	450	550	5	8*19	65	18	53	140
280 (4.6.8)	500	450	550	5	8*19	75	20	67.5	140
315 (4.6.8)	600	550	660	6	8*24	80	22	71	170
355 (4.6.8)	740	680	800	6	8*24	95/ 100	25/28	86/ 90	170/ 210

型号 type	额定功率 roted power KW	转速 rotating	型号 type	额定功率 roted power KW	转速 rotating	型号 type	额定功率 roted power KW	转速 rotating
801-2	0.75	2825	801-4	0.55	1390	801-6	0.37	900
802-2	1.1	2825	802-4	0.75	1390	802-6	0.55	900
90S-2	1.5	2840	90S-4	1.1	1400	Y90S-6	0.75	910
90L-2	2.2	2840	90L-4	1.5	1400	Y90L-6	1.0	910
100L-2	3.0	2880	100L1-4	2.2	1420	Y100L-6	1.5	910
112M-2	4.0	2890	100L2-4	3.0	1420	Y112M-6	2.2	940
132S1-2	5.5	2900	112M-4	4.0	1440	Y132S-6	3.0	960
132S2-2	7.5	2900	132S-4	5.5	1440	Y132M1-6	4.0	960
132M1-2	9.2	2900	132M-4	7.5	1440	Y132M2-6	5.5	960
160M1-2	11	2930	132M2-4	9.2	1460	Y160M-6	7.5	970
160M2-2	15	2930	160M-4	11	1460	Y160L-6	11	970
160L-2	18.5	2930	Y160L-4	15	1460	Y180L-6	15	970
180M-2	22	2940	Y180M-4	18.5	1470	Y200L1-6	18.5	970
200L1-2	30	2950	Y180L-4	22	1470	Y200L2-6	22	970
200L2-2	37	2950	Y200L-4	30	1470	Y225M-6	30	980
225M-2	45	2970	Y225S-4	37	1480	250M-6	37	980
250M-2	55	2970	Y225M-4	45	1480	280S-6	45	980
280S-2	75	2970	250M-4	55	1480	280M1-6	55	980
280M-2	90	2970	280S-4	75	1480	315S-6	75	985
315S-2	110	2970	280M-4	90	1480	315M-6	90	985
315M-2	132	2970	315S-4	110	1480	315L1-6	110	985
315L1-2	160	2970	315M-4	132	1480	315L2-6	132	985
315L2-2	200	2970	315L1-4	160	1480	355M1-6	160	990
355M1-2	220	2980	315L2-4	200	1480	355M2-6	200	990
355M2-2	250	2980	355M1-4	220	1480	355L-6	250	990
355L1-2	280	2980	355M2-4	250	1480			
355L2-2	315	2980	355L1-4	280	1480			
			355L2-4	315	1480			
			355L3-4	355	1480			

NEMA电机法兰标准
NEMA electric motor

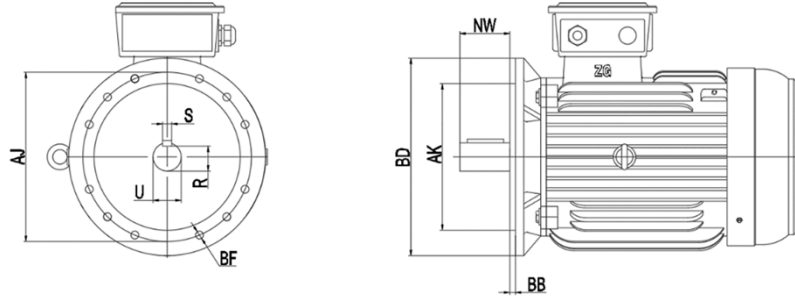

机架	C-法兰								
	BD	AJ	AK	U	R	S	NW	BB	BF
143T 145T	6.5	5.875	4.5	0.875	0.771	0.188	2.25	0.16	4*3/8-16
182T 184T	9	7.25	8.5	1.125	0.986	0.25	2.75	0.25	4*1/2-13
213T 215T	8.95	7.25	8.5	1.375	1.201	0.312	3.38	0.25	4*1/2-13
254T 256T	10	7.25	8.5	1.625	1.416	0.375	4	0.25	4*1/2-13
284T 286T	11.25	9	10.5	1.875	1.591	0.5	4.62	0.25	4*1/2-13
284TS 286TS	11.25	9	10.5	1.625	1.416	0.375	3.25	0.25	4*1/2-13
324T 326T	14	11	12.5	2.125	1.845	0.5	5.25	0.25	4*5/8-11
324TS 326TS	14	11	12.5	1.875	1.591	0.5	3.75	0.25	4*5/8-11
364T 365T	14	11	12.5	2.375	2.021	0.625	5.88	0.25	8*5/8-11
364TS 365TS	14	11	12.5	1.875	1.591	0.5	3.75	0.25	8*5/8-11
404T 405T	15.5	11	12.5	2.875	2.45	0.75	7.25	0.25	8*5/8-11
405TS	15.5	11	12.5	2.125	1.845	0.5	4.25	0.25	8*5/8-11
444T 445T	18	14	16	3.375	2.88	0.875	8.5	0.25	8*5/8-11
444TS 445TS	18	14	16	2.375	2.021	0.625	4.75	0.25	8*5/8-11
447T 449T	18	14	16	3.375	2.88	0.875	8.5	0.25	8*5/8-11
447TS 449TS	18	14	16	2.375	2.021	0.625	4.75	0.25	8*5/8-11

机架	D法兰								
	BD	AJ	AK	U	R	S	NW	BB	BF
143T 145T	11	10	9	0.875	0.771	0.188	2.25	0.25	4*0.53
182T 184T	11	10	9	1.125	0.986	0.25	2.75	0.25	4*0.53
213T 215T	11	10	9	1.375	1.201	0.312	3.38	0.25	4*0.53
254T 256T	14	12.5	11	1.625	1.416	0.375	4	0.25	4*0.81
284T 286T	14	12.5	11	1.875	1.591	0.5	4.62	0.25	4*0.81
284TS 286TS	14	12.5	11	1.625	1.416	0.375	3.25	0.25	4*0.81
324T 326T	18	16	14	2.125	1.845	0.5	5.25	0.25	4*0.81
324TS 326TS	18	16	14	1.875	1.591	0.5	3.75	0.25	4*0.81
364T 365T	18	16	14	2.375	2.021	0.625	5.88	0.25	4*0.81
364TS 365TS	18	16	14	1.875	1.591	0.5	3.75	0.25	4*0.81
404T 405T	22	20	18	2.875	2.45	0.75	7.25	0.25	8*0.81
405TS	22	20	18	2.125	1.845	0.5	4.25	0.25	8*0.81
444T 445T	22	20	18	3.375	2.88	0.875	8.5	0.25	8*0.81
444TS 445TS	22	20	18	2.375	2.021	0.625	4.75	0.25	8*0.81
447T 449T	22	20	18	3.375	2.88	0.875	8.5	0.25	8*0.81
447TS 449TS	22	20	18	2.375	2.021	0.625	4.75	0.25	8*0.81

安装位置 Mounting position

- — 通气帽 Air plug
- — 油镜 Oil view
- — 放油塞 Drain plug

同轴系列 ZL Version

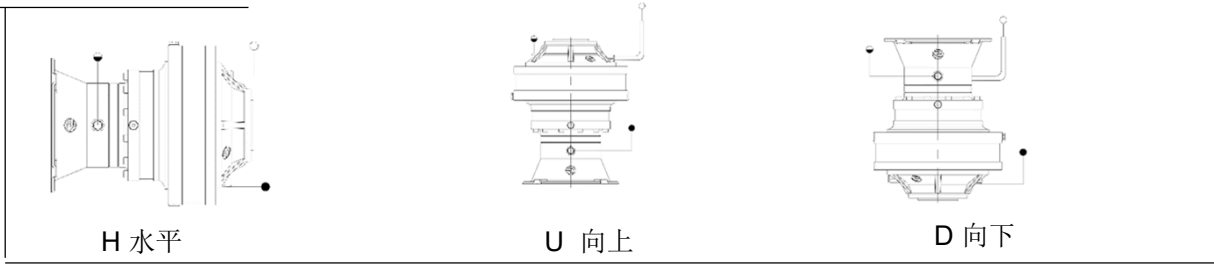

直角系列 ZR Version

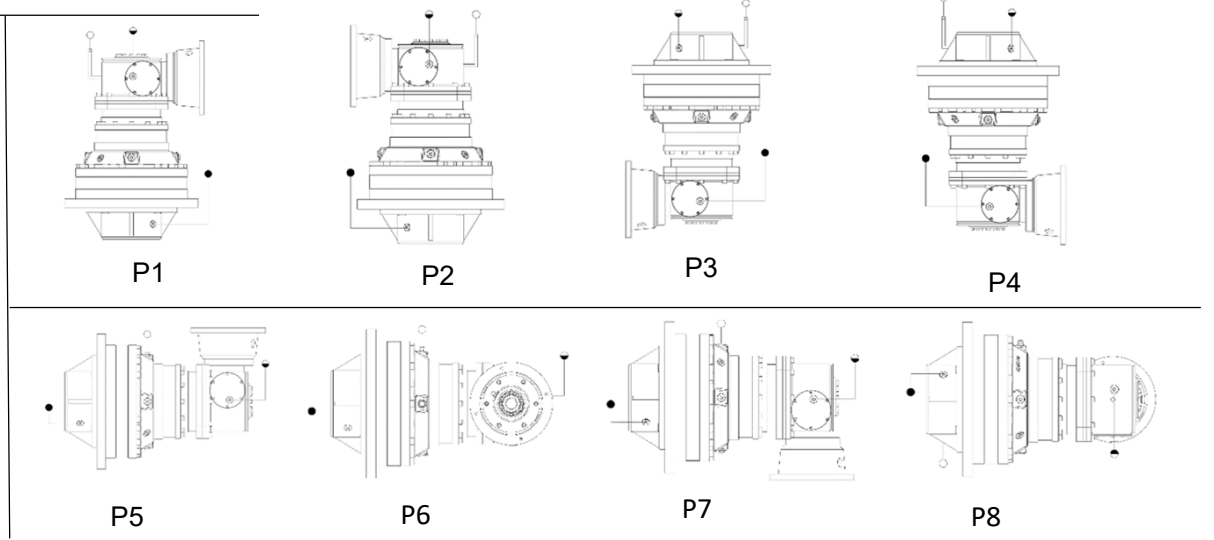

加油量参考表											
型号	H	U/D	型号	H	U/D	型号	H	U/D	型号	H	U/D
ZL01**1	0.4	0.8	ZL10**3	2.4	4.8	ZL35**1	5.4	10.3	ZL85**3	15.0	29.5
ZL01**2	0.5	1.0	ZL10**4	2.6	5.2	ZL35**2	6.2	11.9	ZL85**4	16.5	32.0
ZL01**3	0.7	1.5	ZL16**1	2.7	5.4	ZL35**3	6.5	12.5	ZL95**1	12.0	23.5
ZL01**4	0.8	1.7	ZL16**2	3.0	6.0	ZL35**4	6.7	12.9	ZL95**2	13.5	27.0
ZL02**1	0.5	1.0	ZL16**3	3.2	6.4	ZL45**1	4.8	9.4	ZL95**3	14.5	29.0
ZL02**2	0.6	1.2	ZL16**4	3.4	6.8	ZL45**2	6.9	13.6	ZL95**4	16.0	31.5
ZL02**3	0.7	1.5	ZL19**1	2.7	5.4	ZL45**3	7.3	14.5	ZL120**1	14.0	27.5
ZL02**4	0.8	1.8	ZL19**2	3.0	6.0	ZL45**4	7.4	15.0	ZL120**2	16.0	31.5
ZL03**1	1.0	2.0	ZL19**3	3.4	6.6	ZL55**1	7.5	17.0	ZL120**3	17.0	33.5
ZL03**2	1.2	2.5	ZL19**4	3.5	6.8	ZL55**2	8.5	17.1	ZL120**4	17.3	34.1
ZL03**3	1.3	2.6	ZL24**1	4.4	8.2	ZL55**3	9.1	18.0	ZL150**1	15.0	29.5
ZL03**4	1.4	2.8	ZL24**2	5.0	9.5	ZL55**4	9.4	18.7	ZL150**2	18.5	36.5
ZL06**1	1.2	2.2	ZL24**3	5.2	9.9	ZL75**1	8.8	16.6	ZL150**3	19.7	38.9
ZL06**2	1.3	2.6	ZL24**4	5.5	10.4	ZL75**2	10.7	21.0	ZL150**4	20.1	39.7
ZL06**3	1.5	3.0	ZL30**1	4.3	8.1	ZL75**3	11.5	22.5	ZL200**1	20.5	40.5
ZL06**4	1.6	3.2	ZL30**2	5.1	9.6	ZL75**4	12.0	23.5	ZL200**2	24.0	47.5
ZL10**1	2.1	4.2	ZL30**3	5.3	10.0	ZL85**1	12.5	24.0	ZL200**3	25.0	49.5
ZL10**2	2.3	4.6	ZL30**4	5.5	10.5	ZL85**2	14.0	27.5	ZL200**4	25.5	50.5

重量 单位: 千克
Weight UNIT: KG

型号/TYPE	FS	MS/MF/GS	型号/TYPE	FS	MS/MF/GS
ZL01**1	17	20	ZL35**1	225	239
ZL01**2	22	25	ZL35**2	260	274
ZL01**3	26	30	ZL35**3	280	289
ZL01**4	34	37	ZL35**4	287	305
ZL02**1	16	20	ZL45**1	230	245
ZL02**2	23	27	ZL45**2	315	330
ZL02**3	30	34	ZL45**3	330	350
ZL02**4	37	41	ZL45**4	339	355
ZL03**1	24	35	ZL55**1	305	325
ZL03**2	31	42	ZL55**2	340	360
ZL03**3	38	49	ZL55**3	350	375
ZL03**4	45	56	ZL55**4	357	390
ZL06**1	29	40	ZL75**1	380	410
ZL06**2	38	47	ZL75**2	475	500
ZL06**3	45	56	ZL75**3	510	535
ZL06**4	52	65	ZL75**4	525	555
ZL10**1	60	90	ZL85**1	380	420
ZL10**2	44	108	ZL85**2	475	515
ZL10**3	86	115	ZL85**3	510	550
ZL10**4	93	124	ZL85**4	525	565
ZL16**1	86	125	ZL95**1	415	455
ZL16**2	102	142	ZL95**2	510	540
ZL16**3	110	149	ZL95**3	540	580
ZL16**4	117	156	ZL95**4	555	595
ZL19**1	87	125	ZL120**1	650	700
ZL19**2	105	142	ZL120**2	710	760
ZL19**3	120	155	ZL120**3	730	780
ZL19**4	125	163	ZL120**4	745	795
ZL24**1	150	185	ZL150**1	665	715
ZL24**2	180	215	ZL150**2	725	775
ZL24**3	194	228	ZL150**3	745	795
ZL24**4	201	235	ZL150**4	760	810
ZL30**1	150	185	ZL200**1	885	935
ZL30**2	200	230	ZL200**2	1075	1125
ZL30**3	207	242	ZL200**3	1125	1175
ZL30**4	216	252	ZL200**4	1150	1200

注: 不包括附属零件重量.
Note: Not contain attached parts weight.



志存高远 脚踏实地
Fly Dream Hard Work

长驰传动科技（苏州）有限公司 Z-Gallop Transmission Technology (SuZhou) co.,Ltd
地址:江苏省昆山市高新区晨丰东路228-7号 Add:NO. 228-7 ChenFeng East RD.Kunshan Jiangsu China
电话Tel:0512-57383189 传真Fax:0512-50169658 E-mail:zginfo@z-gallop.com www.z-gallop.com



品质驱动未来 QUANLITY DRIVE FUTURE